

RAYTOOLS

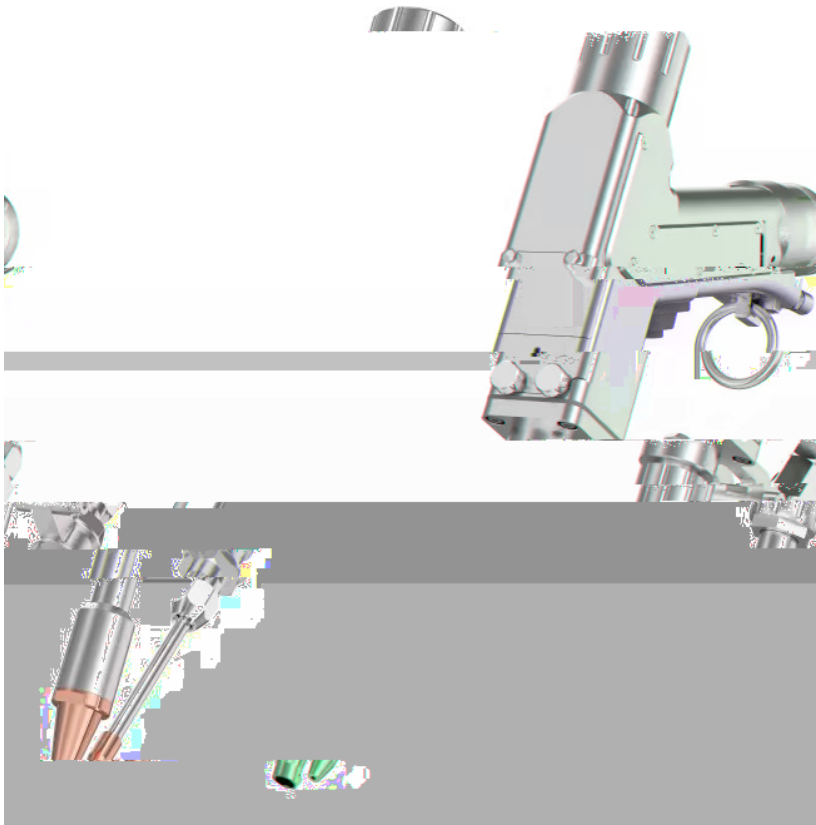

()



■

- -
 -
 -
 -
-

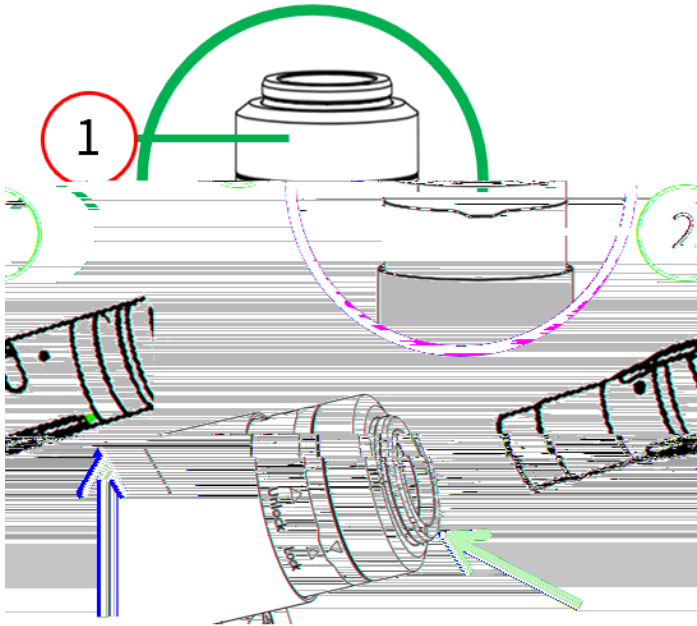

2.4.1

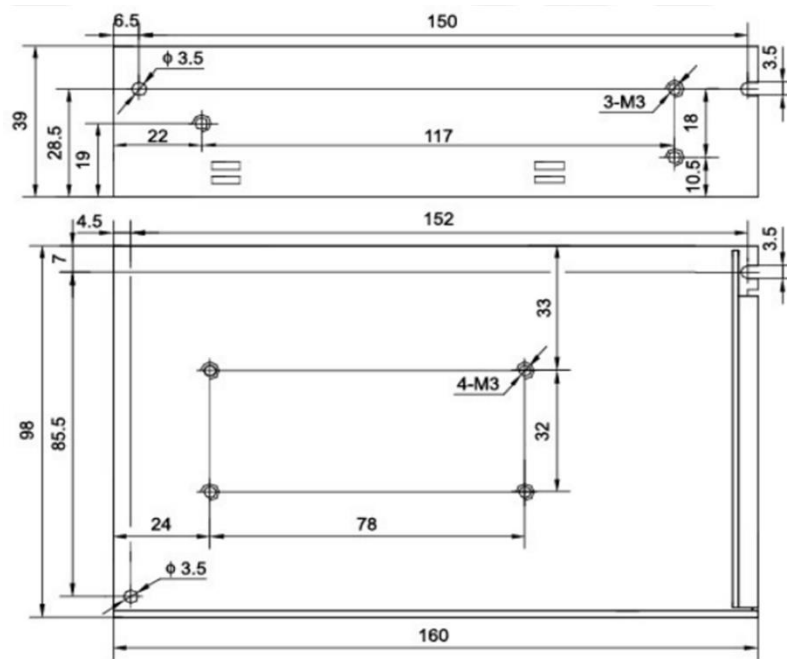
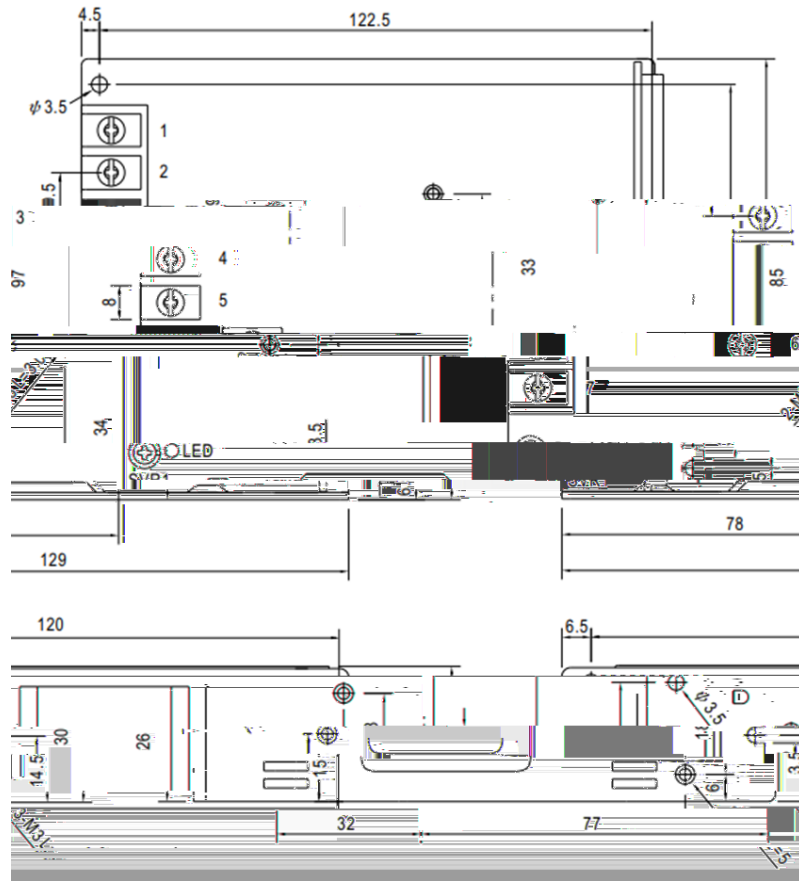

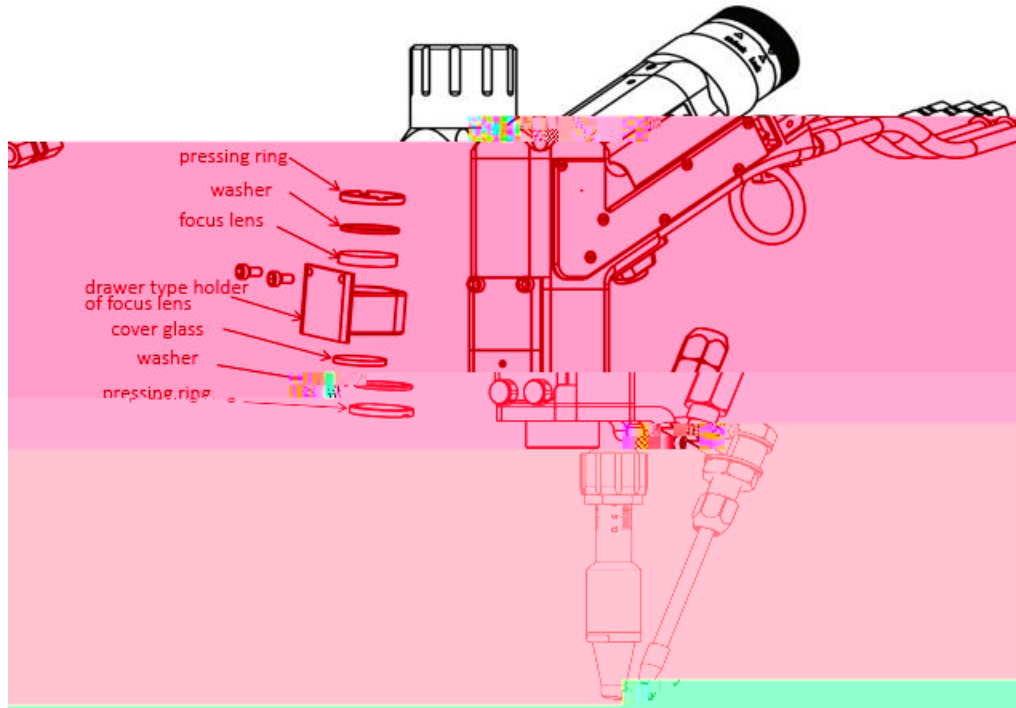

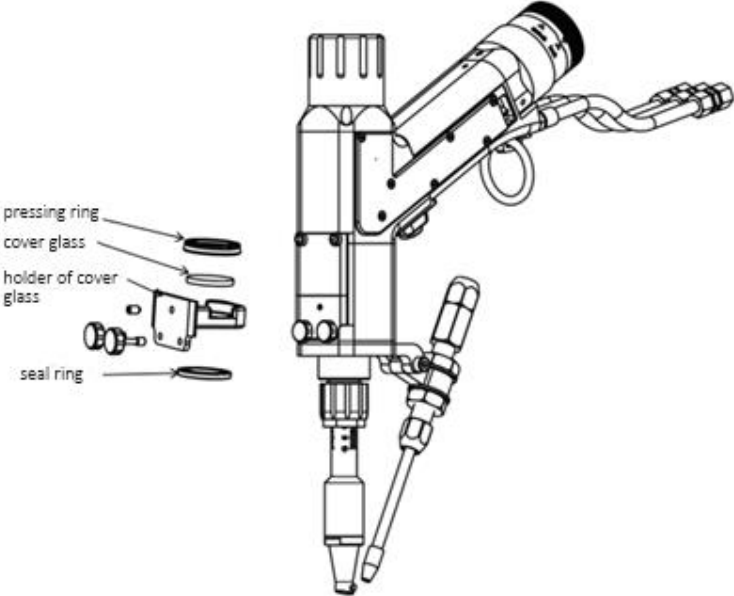

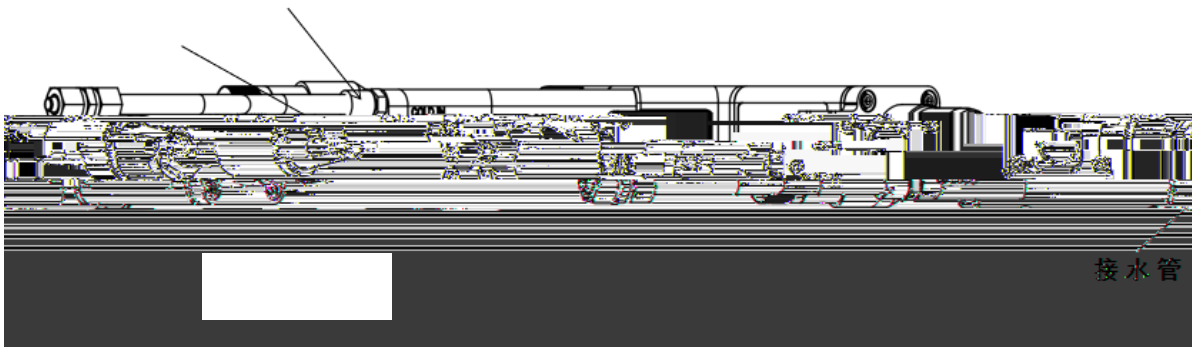

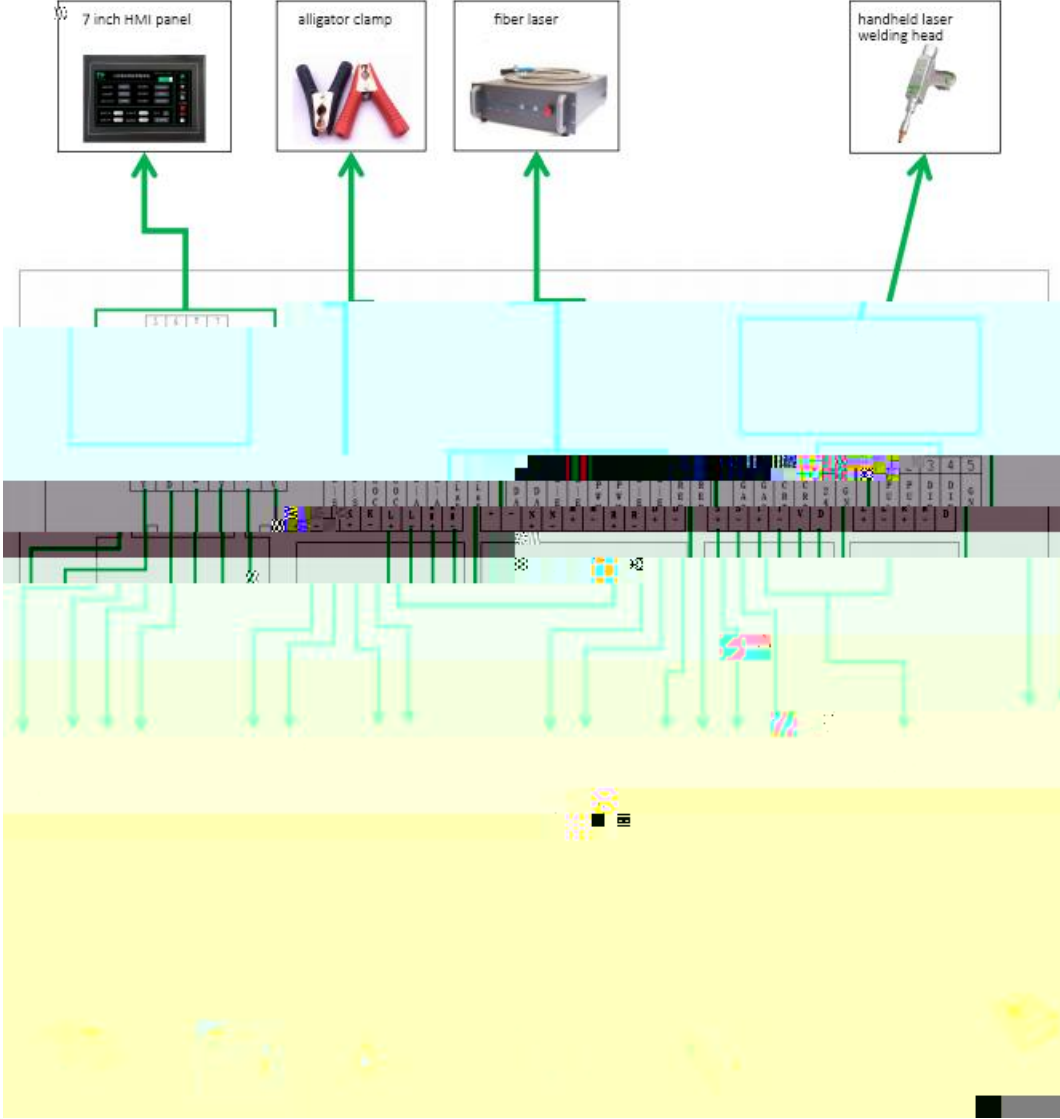

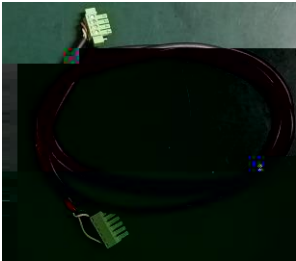
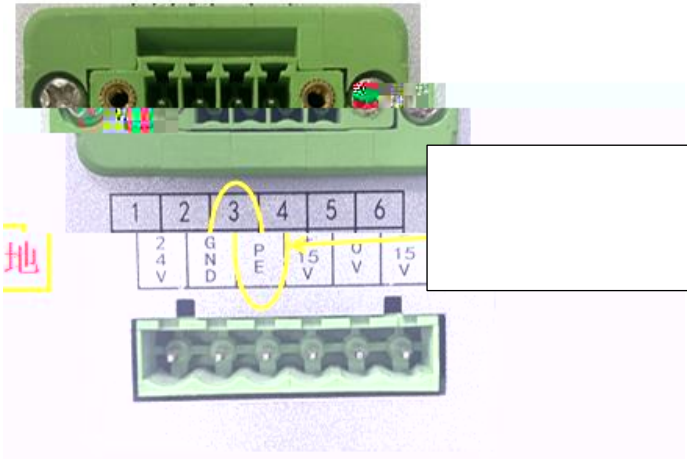

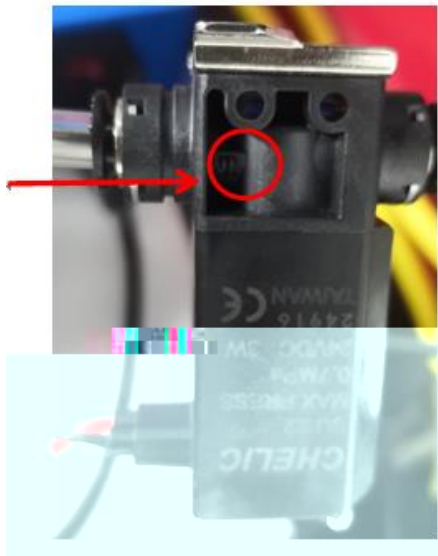
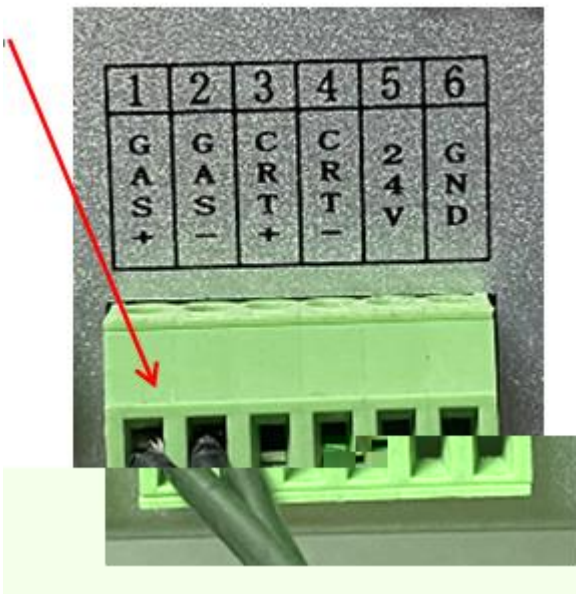
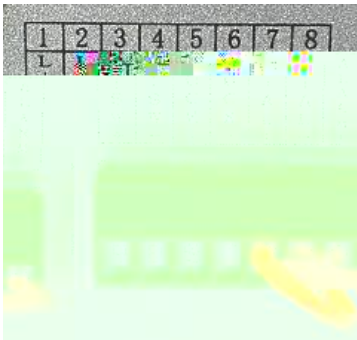

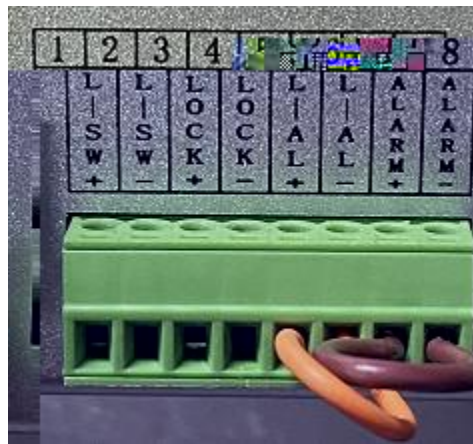
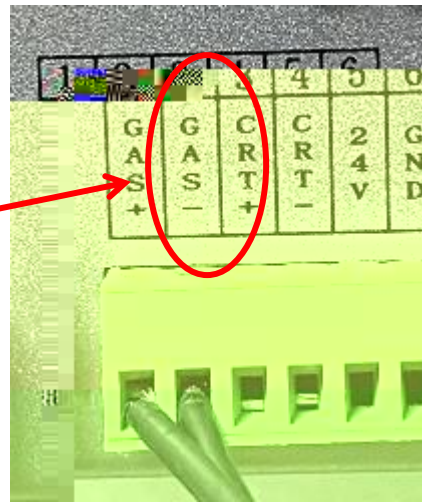
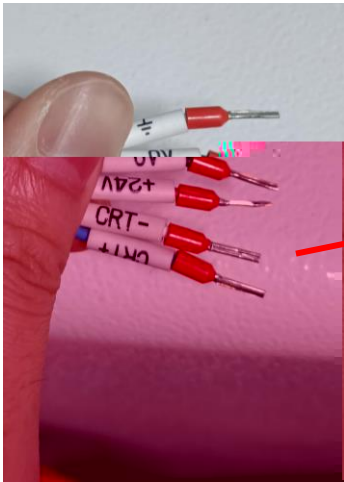

RAYTOOLS

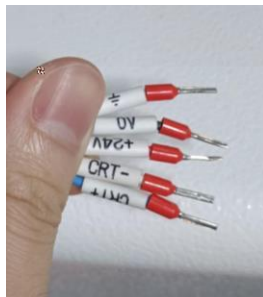
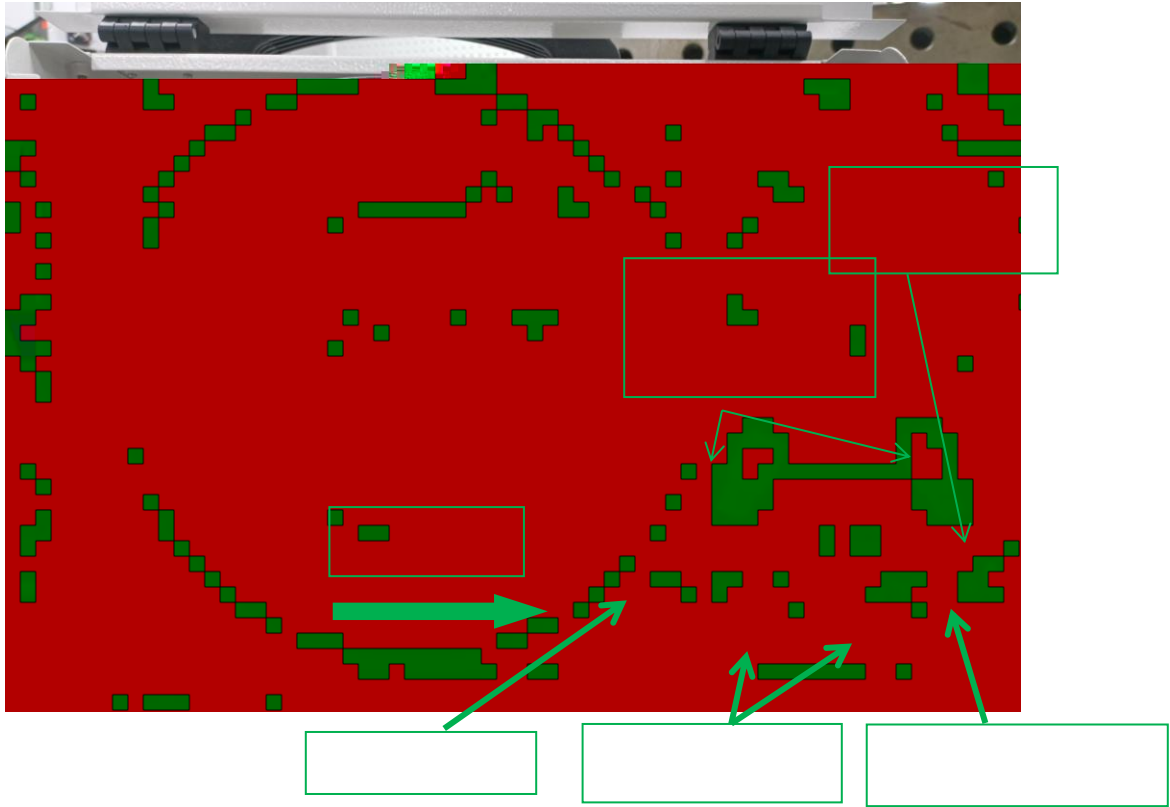

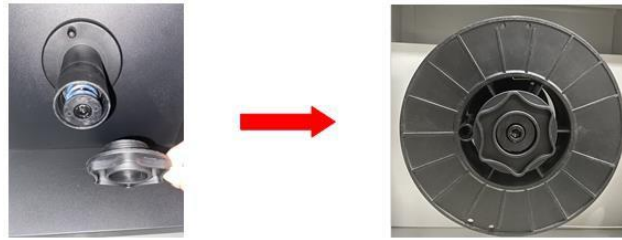

Tension Regulator Released

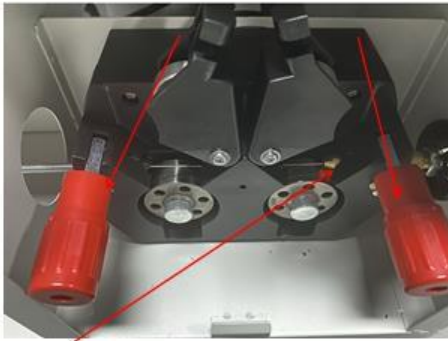

Tension Regulator Tightened

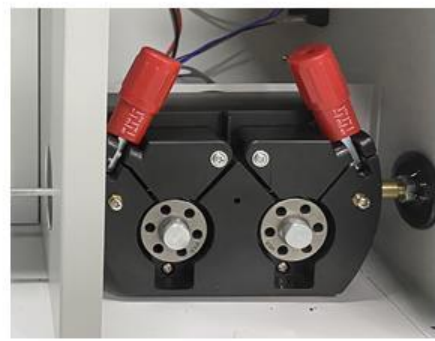

Wire Lead

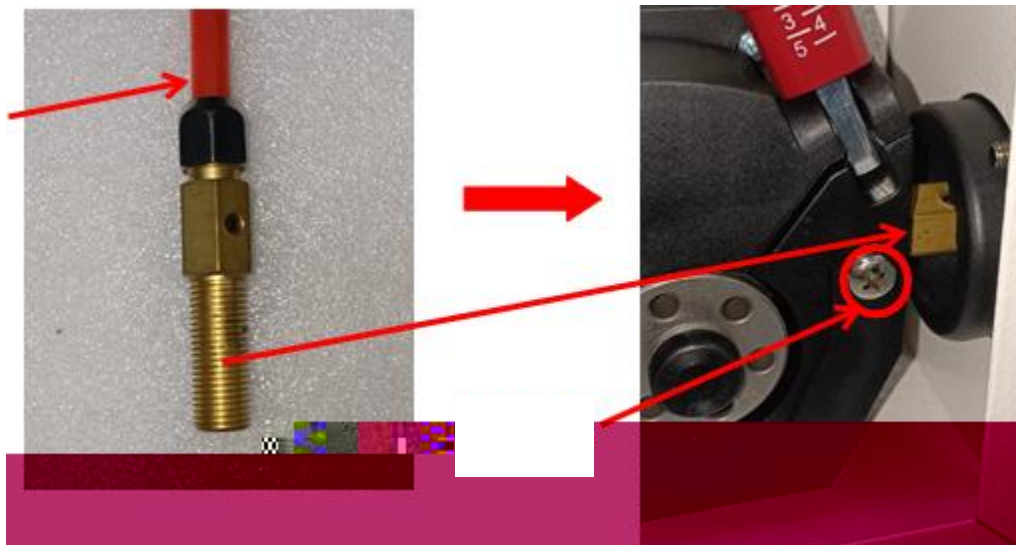



	()

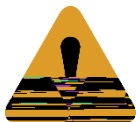
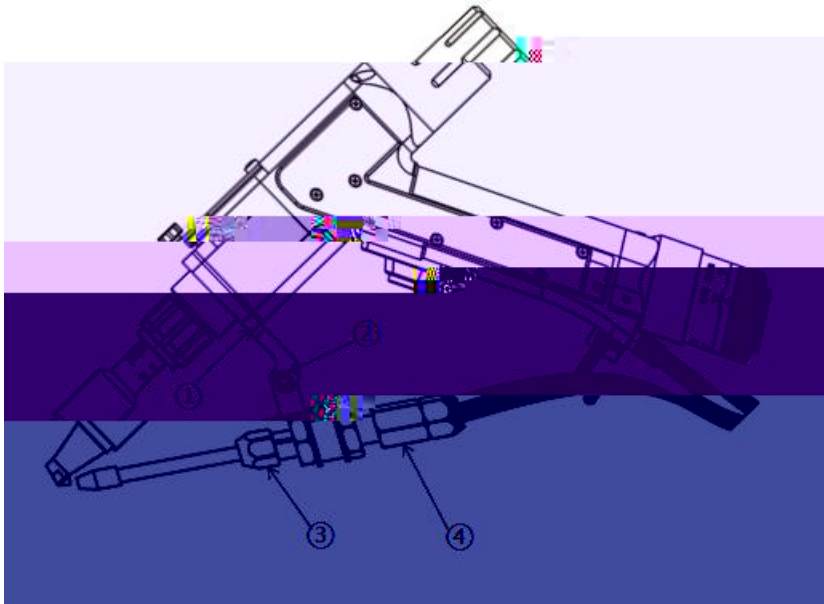

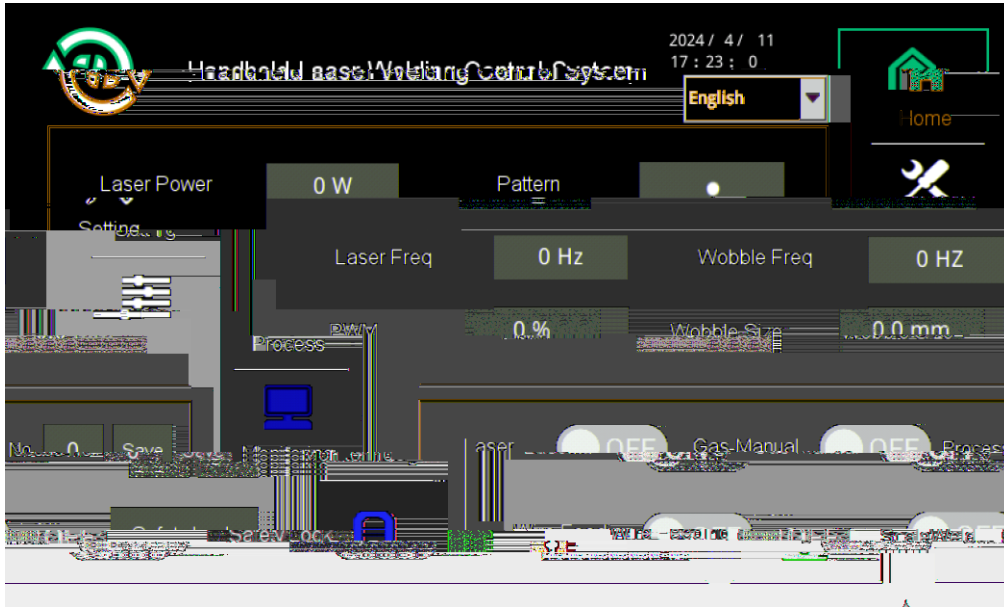

Laser Power

Pattern

Laser Freq

Wobble Freq

PWM

Wobble Size

Laser





Gas in Advance

Gas Delay

Beam Off Delay

On Power

Off Power

Ascend

Descend

Max Power

Alarm Signal

NozzleBreak Duration

ScaleWeld Duration

ScaleWeld Interval

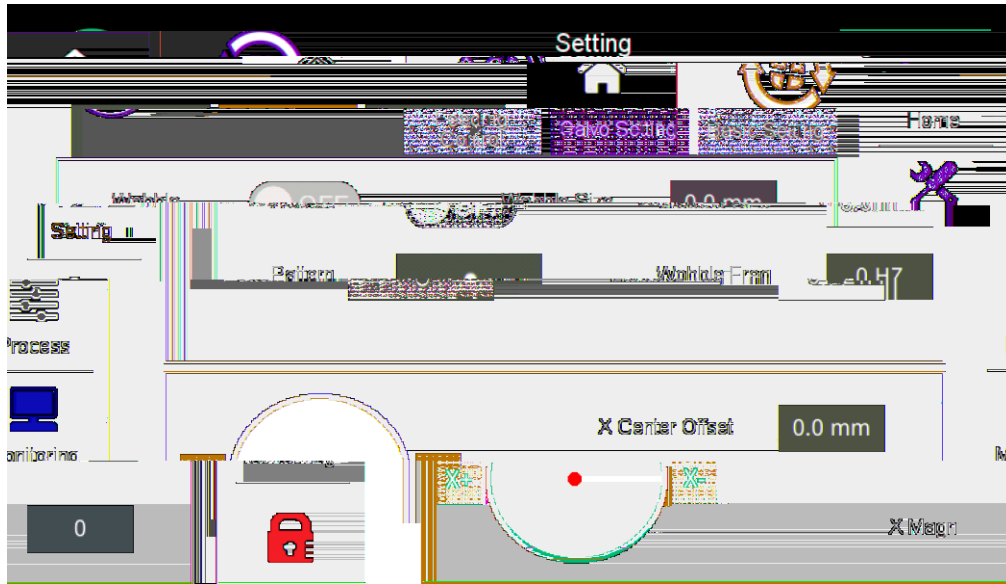

A



Pattern

Wobble Size

Wobble Freq

X Center Offset

X Magn

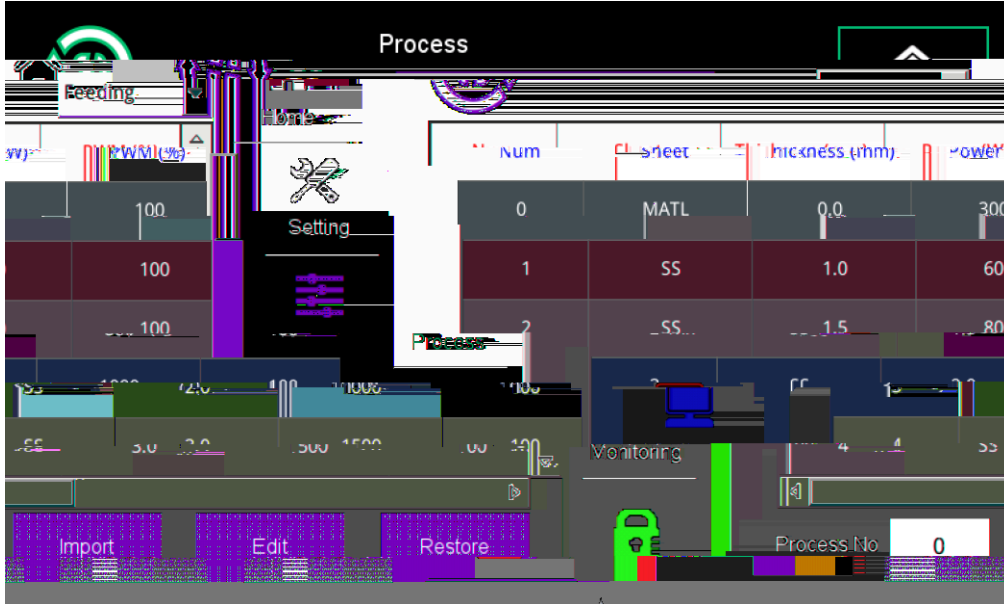

Feeding ▼

Process No 0

Import

Edit

Restore

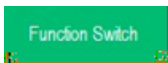
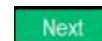
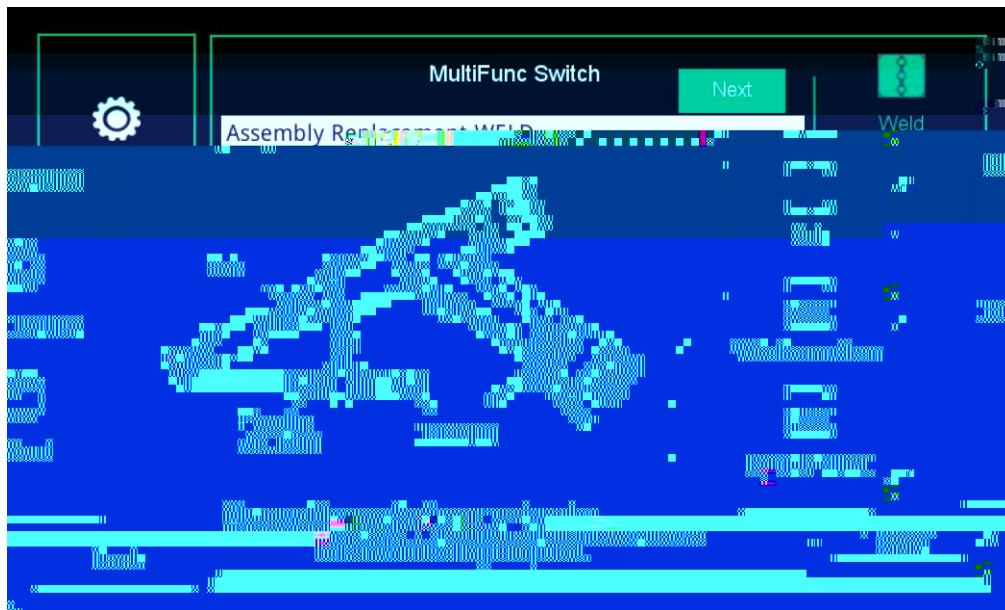

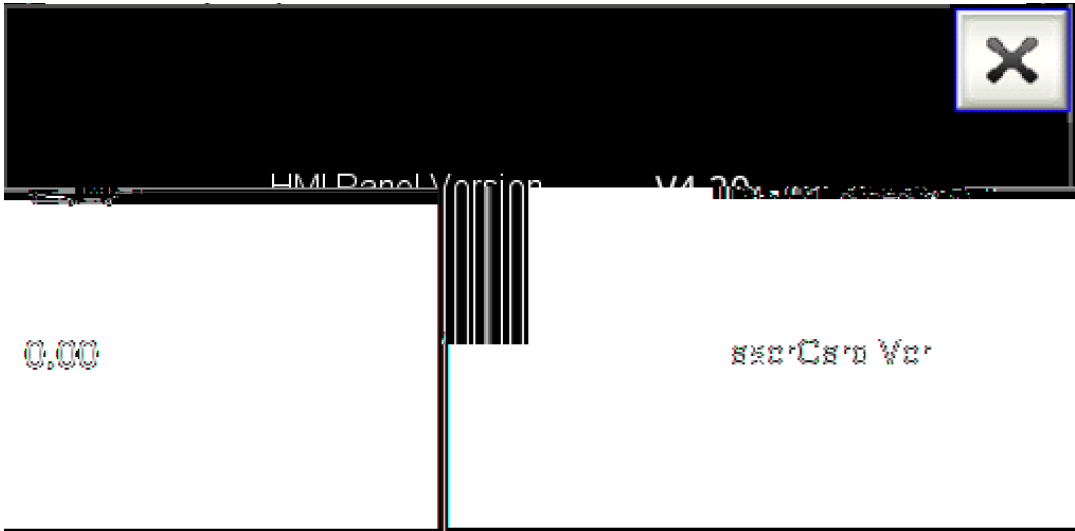

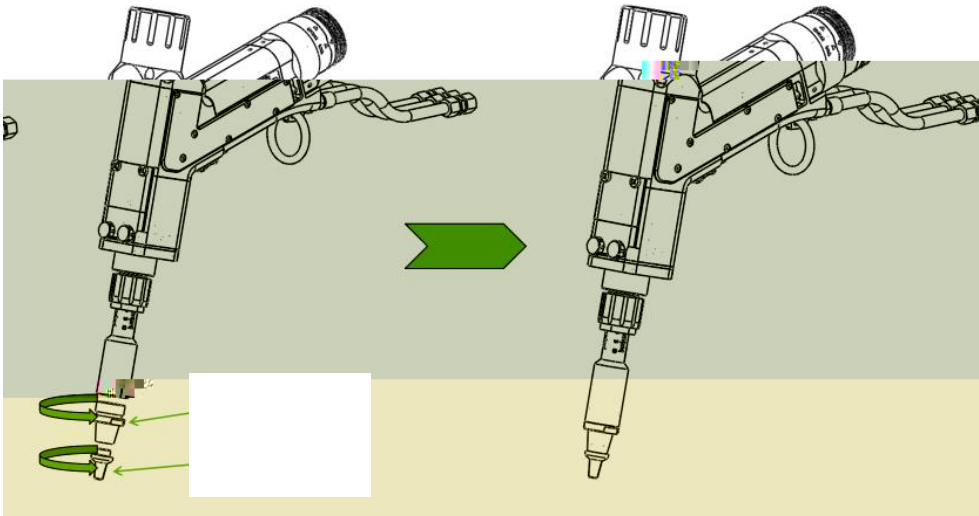



X Center Offset

X Magn

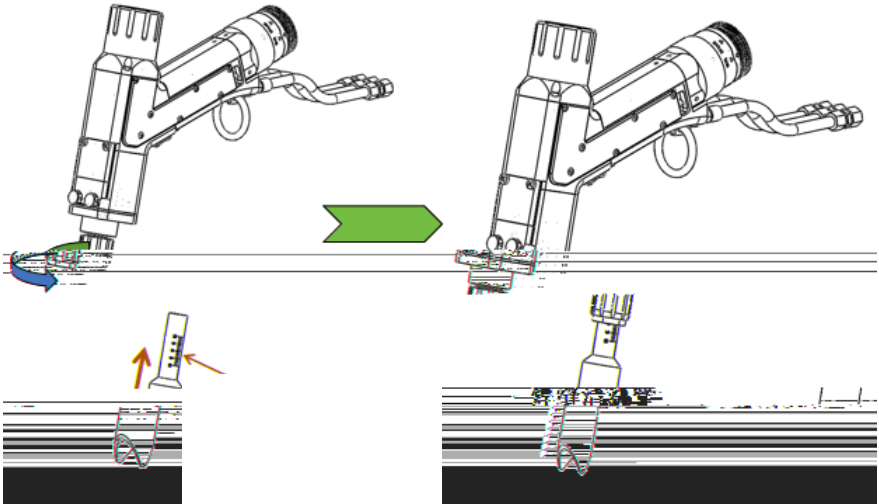

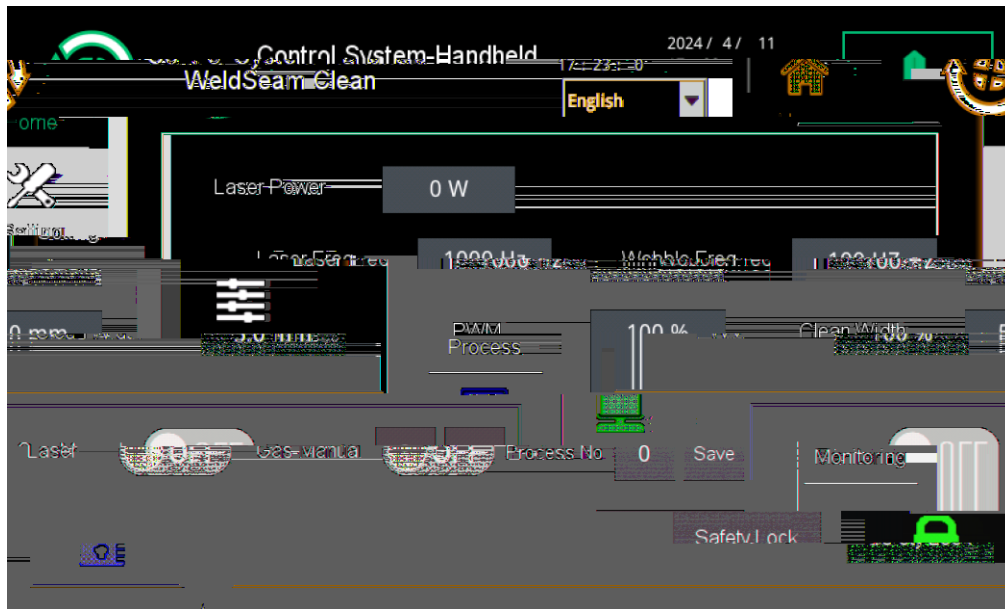

Laser Power

Laser Freq

Wobble Freq

PWM

Clean Width

Laser OFF

Gas-Manual OFF

Process No 0

Safety Lock

RAYTOOLS

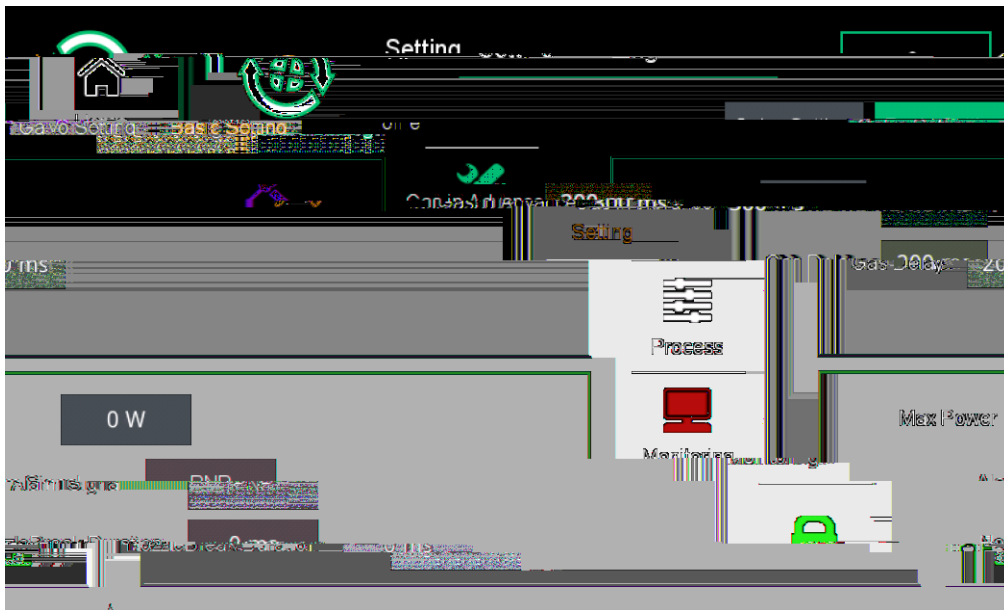

Gas in Advance

Gas Delay

Max Power

Alarm Signal

NozzleBreak Duration



Wobble Size

Wobble Freq

X Center Offset

X Magn

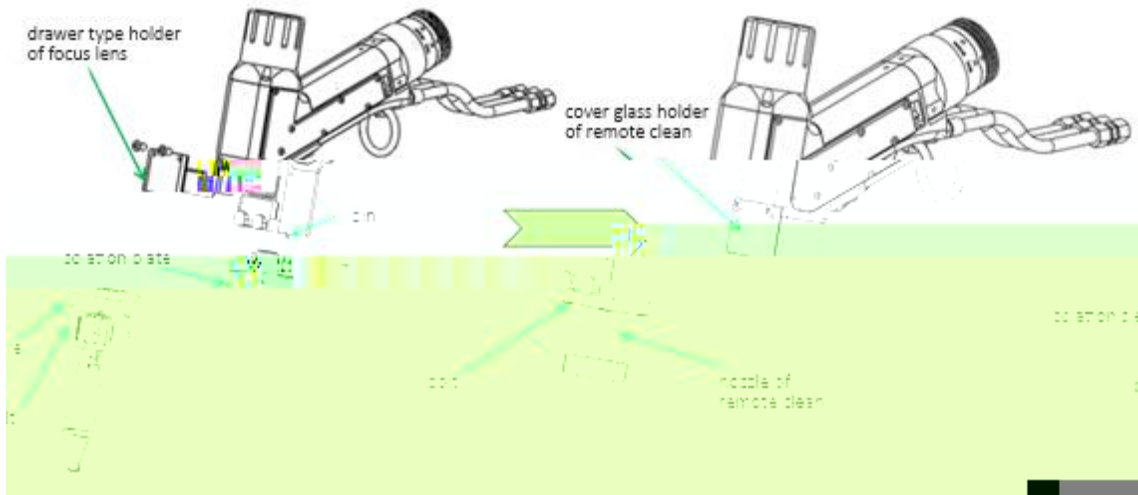

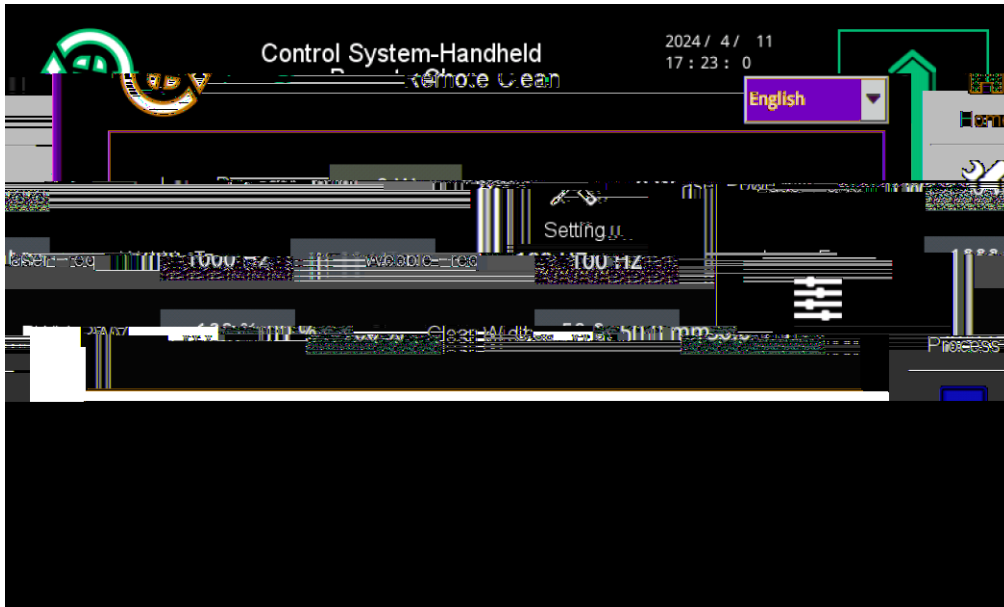

Laser Power

Laser Freq

Wobble Freq

PWM

Clean Width

Laser OFF

Gas-Manual OFF

Process No

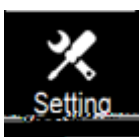

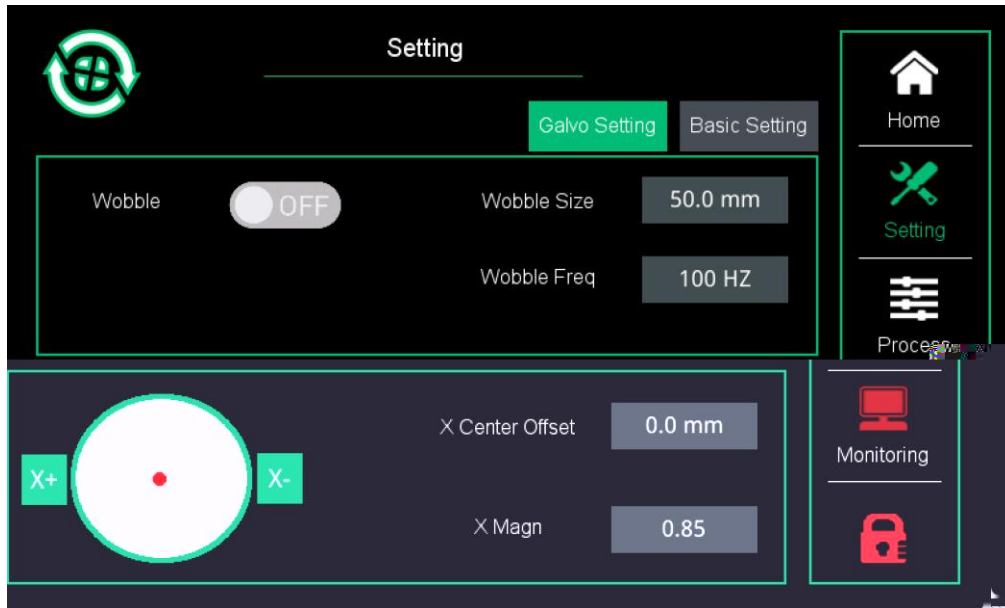



Wobble





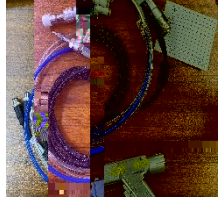
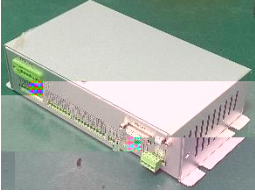
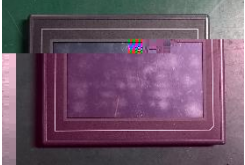

Wobble Size

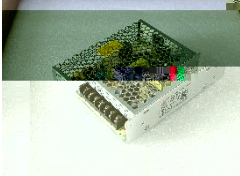

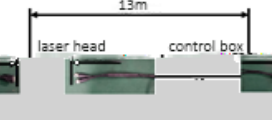
Wobble Freq







X Center Offset



















X Magn

				
) (
				
				
				
				
	()			

	()		 
			
			
			
			
			

		
		

.

--	--	--

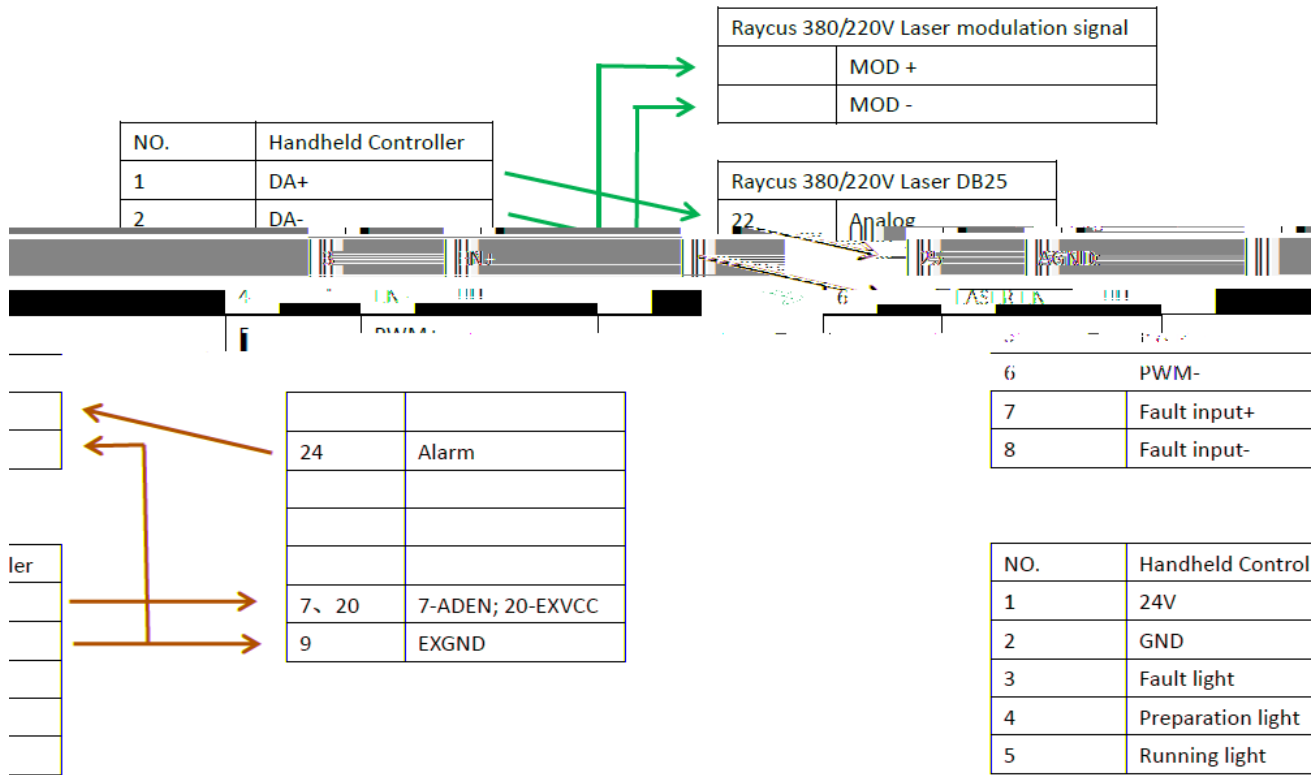

.
